

FORM TP 2016089



TEST CODE **01234020**

MAY/JUNE 2016

**CARIBBEAN EXAMINATIONS COUNCIL
CARIBBEAN SECONDARY EDUCATION CERTIFICATE®
EXAMINATION**

MATHEMATICS

Paper 02 – General Proficiency

2 hours 40 minutes

READ THE FOLLOWING INSTRUCTIONS CAREFULLY.

1. This paper consists of TWO sections: I and II.
2. Section I has EIGHT questions and Section II has THREE questions.
3. Answer ALL questions in Section I, and any TWO questions from Section II.
4. Write your answers in the booklet provided.
5. Do NOT write in the margins.
6. All working MUST be shown clearly.
7. **A list of formulae is provided on page 2 of this booklet.**
8. If you need to rewrite any answer and there is not enough space to do so on the original page, you must use the extra page(s) provided at the back of this booklet. **Remember to draw a line through your original answer.**
9. **If you use the extra page(s) you MUST write the question number clearly in the box provided at the top of the extra page(s) and, where relevant, include the question part beside the answer.**

Required Examination Materials

Electronic calculator
Geometry set

DO NOT TURN THIS PAGE UNTIL YOU ARE TOLD TO DO SO.

Copyright © 2014 Caribbean Examinations Council
All rights reserved.

01234020/F 2016



0123402003

LIST OF FORMULAE

Volume of a prism $V = Ah$ where A is the area of a cross-section and h is the perpendicular length.

Volume of cylinder $V = \pi r^2 h$ where r is the radius of the base and h is the perpendicular height.

Volume of a right pyramid $V = \frac{1}{3} Ah$ where A is the area of the base and h is the perpendicular height.

Circumference $C = 2\pi r$ where r is the radius of the circle.

Arc length $S = \frac{\theta}{360} \times 2\pi r$ where θ is the angle subtended by the arc, measured in degrees.

Area of a circle $A = \pi r^2$ where r is the radius of the circle.

Area of a sector $A = \frac{\theta}{360} \times \pi r^2$ where θ is the angle of the sector, measured in degrees.

Area of trapezium $A = \frac{1}{2} (a + b) h$ where a and b are the lengths of the parallel sides and h is the perpendicular distance between the parallel sides.

Roots of quadratic equations If $ax^2 + bx + c = 0$,

$$\text{then } x = \frac{-b \pm \sqrt{b^2 - 4ac}}{2a}$$

Trigonometric ratios

$$\sin \theta = \frac{\text{opposite side}}{\text{hypotenuse}}$$

$$\cos \theta = \frac{\text{adjacent side}}{\text{hypotenuse}}$$

$$\tan \theta = \frac{\text{opposite side}}{\text{adjacent side}}$$

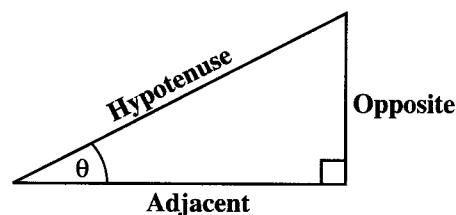

Area of triangle

Area of $\Delta = \frac{1}{2} bh$ where b is the length of the base and h is the perpendicular height.

$$\text{Area of } \Delta ABC = \frac{1}{2} ab \sin C$$

$$\text{Area of } \Delta ABC = \sqrt{s(s-a)(s-b)(s-c)}$$

$$\text{where } s = \frac{a+b+c}{2}$$

Sine rule

$$\frac{a}{\sin A} = \frac{b}{\sin B} = \frac{c}{\sin C}$$

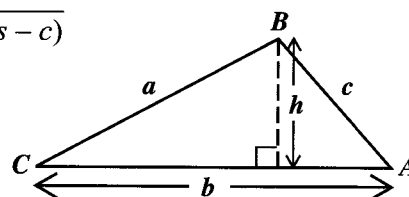

Cosine rule

$$a^2 = b^2 + c^2 - 2bc \cos A$$

GO ON TO THE NEXT PAGE



SECTION I

Answer ALL questions in this section.

All working must be clearly shown.

1. (a) Using a calculator, or otherwise, calculate

(i) $\frac{3\frac{3}{8} - 2\frac{1}{4}}{1\frac{1}{2}}$ giving your answer as a fraction in its lowest terms.

(2 marks)

- (ii) $(2.86 + 0.75) + 0.481^2$ giving your answer correct to 2 decimal places.

(2 marks)

GO ON TO THE NEXT PAGE



- (b) Paul bought and sold a computer. He wrote his business activity as follows:

Cost price of computer = \$1064

Marked price of computer = \$1399

Discount on marked price = 5%
(if paid by cash)

Calculate

- (i) the selling price (paid cash)

(2 marks)

- (ii) the profit or loss as a percentage of the cost price.

(2 marks)

GO ON TO THE NEXT PAGE



- (c) Orange juice is sold in cartons of three different sizes.

Carton Size	Selling Price
350 ml	\$4.20
450 ml	\$5.35
500 ml	\$5.80

Which size of orange juice is the most cost-effective buy? **Justify your answer.**

(3 marks)

Total 11 marks



2. (a) Factorize completely:

(i) $4a^2 - 16$

(2 marks)

(ii) $3y^2 + 2y - 8$

(2 marks)

(b) Solve the simultaneous equations:

$$2x + y = 3$$

$$5x - 2y = 12$$

(5 marks)

GO ON TO THE NEXT PAGE



DO NOT WRITE IN THIS AREA

DO NOT WRITE IN THIS AREA

DO NOT WRITE IN THIS AREA

- (c) The table below shows corresponding values of the variables x and y , where y varies directly as x .

x	6	10	t
y	3	u	9

Calculate the values of t and u .

(3 marks)

Total 12 marks



3. (a) The Venn diagram below shows the number of students who study History and French in a class of 30 students.

$U = \{\text{students in the class}\}$
 $H = \{\text{students who study History}\}$
 $F = \{\text{students who study French}\}$

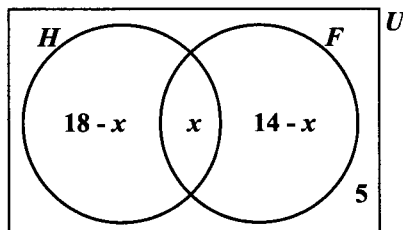

- (i) Write an expression, in x , in its simplest form, for the TOTAL number of students in the class.

.....
 (2 marks)

- (ii) State whether the following relationships are true or false:

- $H \cup F = U$
 - $H \cap F' = \emptyset$
- (2 marks)

- (iii) Determine the number of students who study BOTH History and French.

(2 marks)

GO ON TO THE NEXT PAGE



DO NOT WRITE IN THIS AREA

- (b) (i) Using a ruler, a pencil and a pair of compasses, construct triangle PQR with $PQ = 5$ cm, $\angle PQR = 60^\circ$ and $\angle QPR = 90^\circ$.

(4 marks)

- (ii) Measure and state

- the length of PR

$PR =$

- the measure of $\angle PRQ$.

$\angle PRQ =$

(2 marks)

Total 12 marks

GO ON TO THE NEXT PAGE



DO NOT WRITE IN THIS AREA

4. The diagram below, **not drawn to scale**, shows a silver box with no lid. The sides and bottom of the box are 1.5 cm thick.

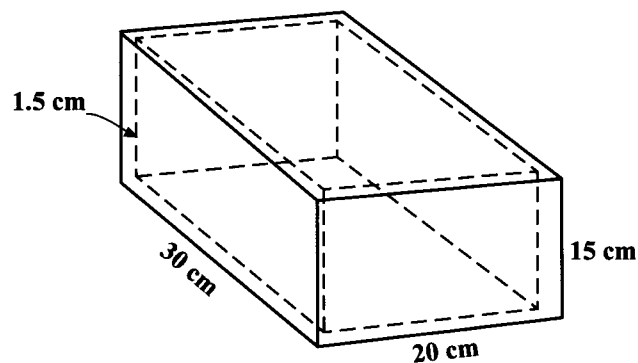

- (a) Calculate the volume of the box using the external measurements.

(2 marks)

- (b) Complete EACH of the following statements.

(i) The internal length of the box is $30 \text{ cm} - 2 \times 1.5 \text{ cm} = \dots\dots\dots$ (1 mark)

(ii) The internal width of the box is $\dots\dots\dots$ (2 marks)

(iii) The internal depth of the box is $\dots\dots\dots$ (1 mark)

GO ON TO THE NEXT PAGE



DO NOT WRITE IN THIS AREA

- (c) Calculate the internal volume of the box.

(2 marks)

- (d) The box is made of silver which has a mass of 10.5 g for each cm^3 . Calculate the mass of the silver box, giving your answer in kg.

(3 marks)

Total 11 marks



5. (a) The diagram below, **not drawn to scale**, shows two straight lines, JK and JL , intersecting a pair of parallel lines, EF and GH .

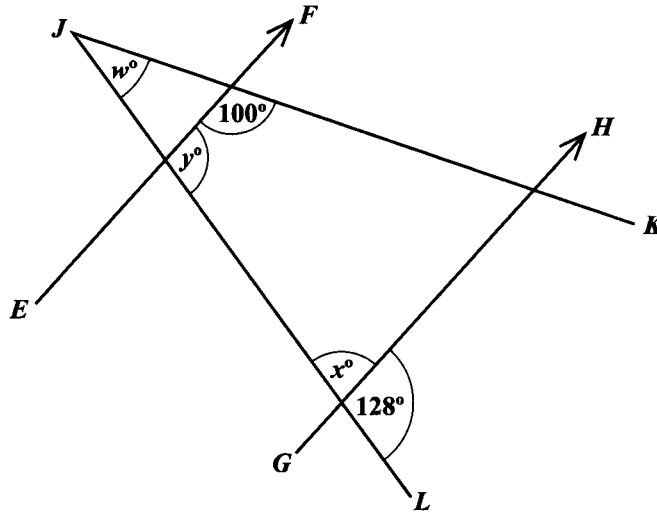

Determine, giving reasons for EACH of your answers, the value of

- (i) x

..... (2 marks)

- (ii) y

..... (2 marks)

- (iii) w .

..... (2 marks)

GO ON TO THE NEXT PAGE



DO NOT WRITE IN THIS AREA

- (b) The diagram below shows triangle RST and its image $R'S'T'$ after a transformation.

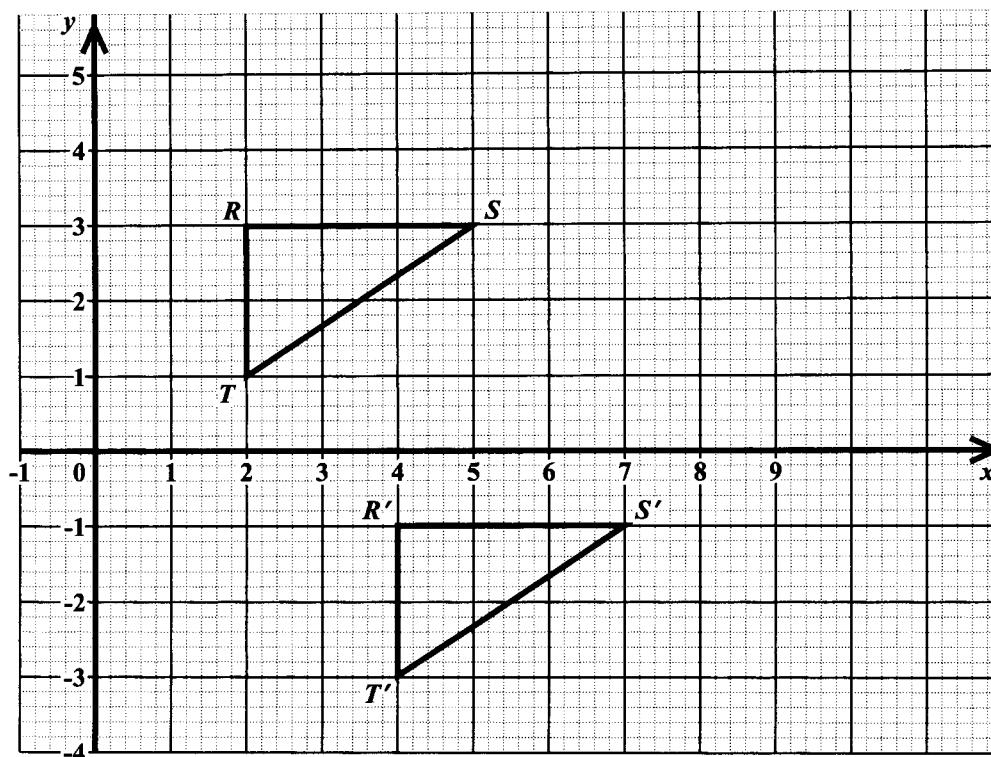

- (i) Describe FULLY the transformation which maps RST onto $R'S'T'$.

.....

(3 marks)

- (ii) Triangle RST is reflected in the line $x = 6$. On the graph above, draw triangle $R''S''T''$, the image of $\triangle RST$, after the reflection.

Write down the coordinates of R'' .

$R'' =$

(3 marks)

Total 12 marks



DO NOT WRITE IN THIS AREA

6. (a) The diagram below shows the graph of the straight line $x + y = 3$.

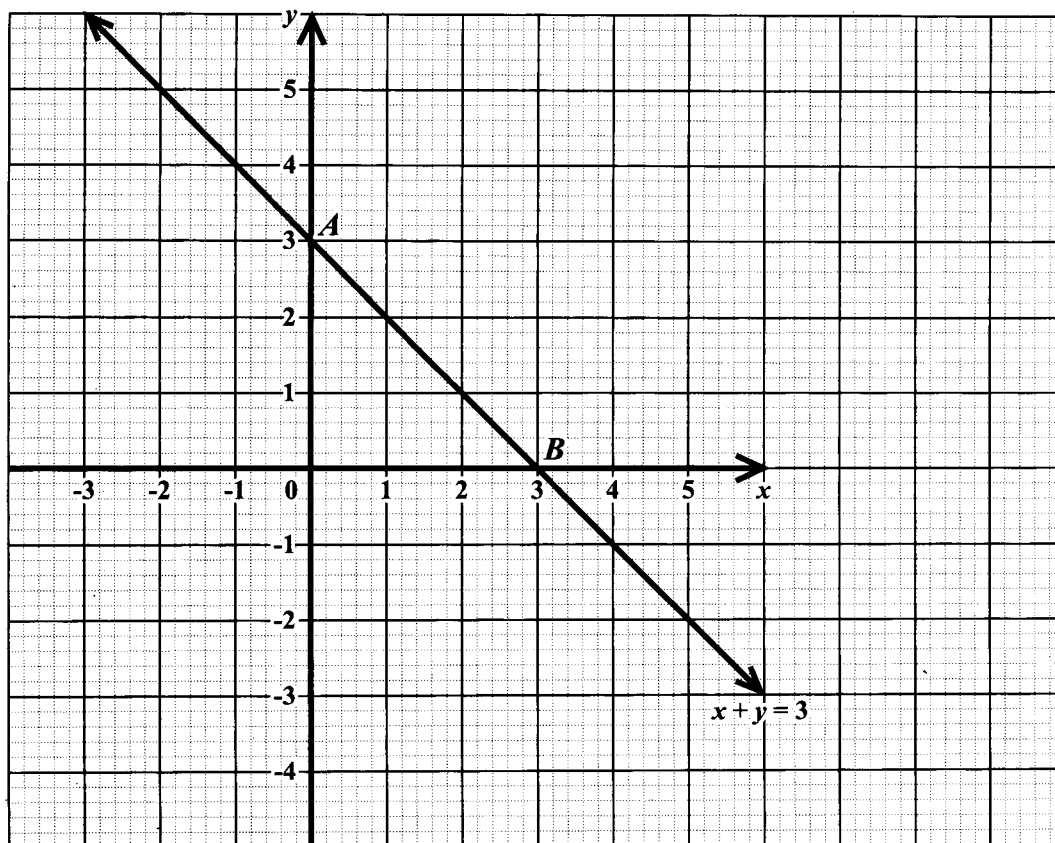

Determine the equation of the line which is

- (i) parallel to the line $x + y = 3$ and passes through the origin

(2 marks)

- (ii) perpendicular to the line $x + y = 3$ and passes through the midpoint of AB.

(2 marks)

GO ON TO THE NEXT PAGE



DO NOT WRITE IN THIS AREA

- (b) The function $y = x^2 - 2x - 3$ is defined in the domain $-2 \leq x \leq 4$. The table below shows the corresponding values of y for five selected values of x .

x	-2	-1	0	1	2	3	4
y	5	0	-3		-3		5

- (i) Complete the table by calculating and inserting the missing values of y .

(2 marks)

- (ii) On the same axes used in Part (a) on page 16, draw the graph of $y = x^2 - 2x - 3$.
(2 marks)

- (iii) Using information from your graph, complete EACH of the following statements.

• The minimum value of $y = x^2 - 2x - 3$ occurs when $x =$
(1 mark)

• The values of x for which $x^2 - 2x - 3 = -x + 3$ are $x =$
and $x =$
(2 marks)

Total 11 marks

GO ON TO THE NEXT PAGE



7. Twenty bags of sugar were weighed. The weights, to the nearest kg, are as follows:

3	38	17	33	28
12	43	38	31	30
11	8	23	18	26
50	22	35	39	5

- (a) Complete the frequency table for the data shown above.

Weight (kg)	Tally	Number of Bags
1–10		
11–20		
21–30		
31–40		
41–50		

(4 marks)

- (b) For the class interval 21–30, state:

(i) the upper class boundary

..... (1 mark)

(ii) the class width

..... (1 mark)

(iii) the class midpoint

..... (1 mark)

- (c) On the grid on page 19, using a scale of **2 cm to represent 10 kg on the x-axis**, and **1 cm to represent 1 bag on the y-axis**, draw a histogram to represent the data contained in your frequency table above. (4 marks)

Total 11 marks

GO ON TO THE NEXT PAGE



DO NOT WRITE IN THIS AREA

DO NOT WRITE IN THIS AREA

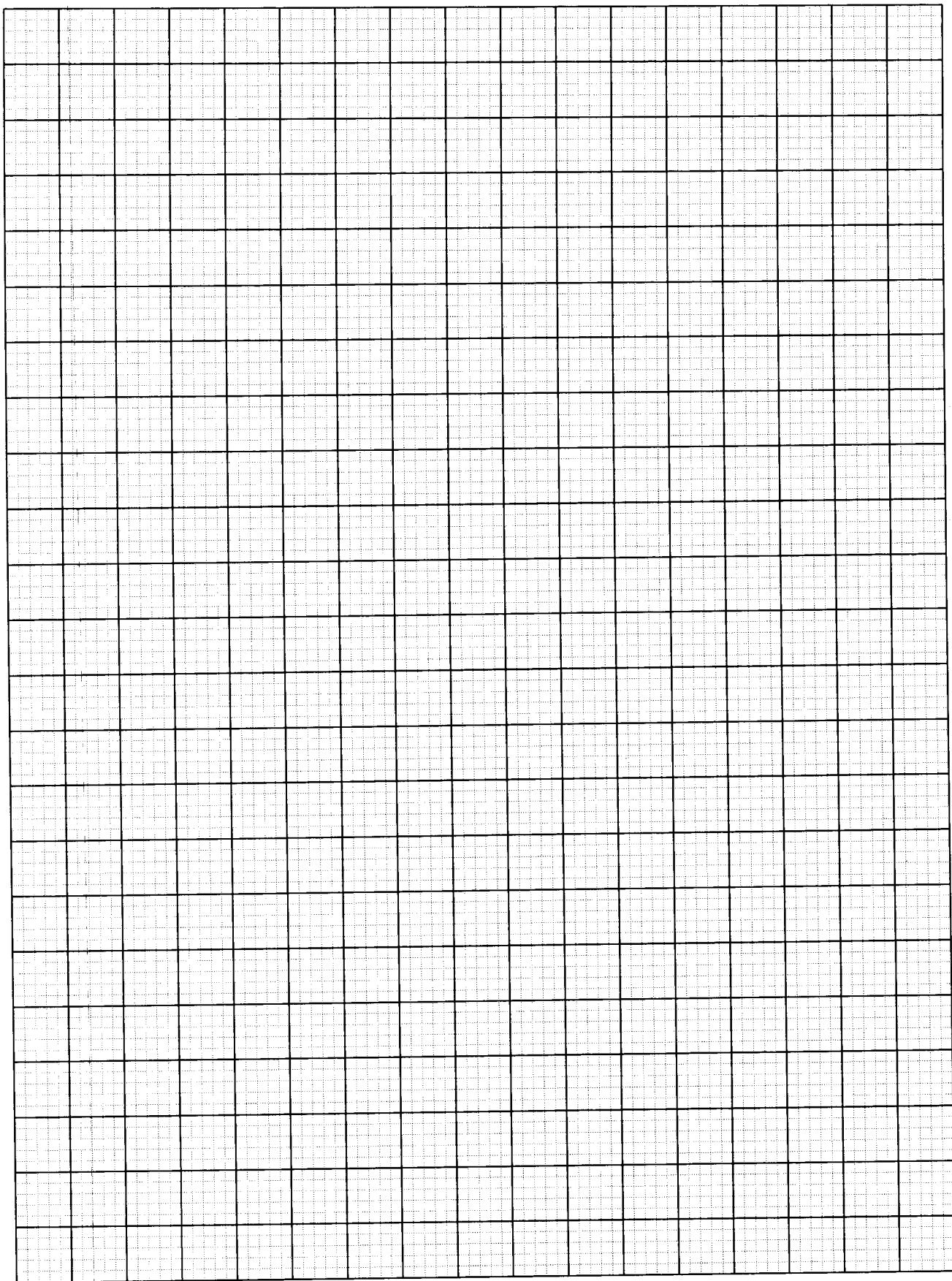

GO ON TO THE NEXT PAGE



8. The diagram below shows the first three figures in a sequence. Each figure is made up of knots and strings. Each knot connects exactly 3 strings.

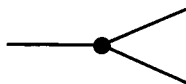

Figure 1

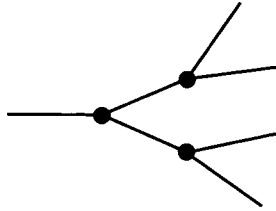

Figure 2

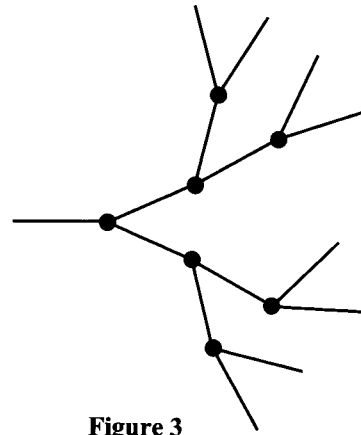

Figure 3

- (a) Draw Figure 4 of the sequence.

(2 marks)

Figure 4



DO NOT WRITE IN THIS AREA

- (b) The table below shows the number of knots and strings in each figure used to draw Figures 1, 2 and 3. Complete the table by inserting the missing values in the rows numbered (i), (ii) and (iii).

	Figure Number (N)	Number of Knots (K)	Number of Strings (S)	
	1	1	3	
	2	3	7	
	3	7	15	
(i)	4	(2 marks)
(ii)	255	(3 marks)
(iii)	10	(3 marks)

Total 10 marks

GO ON TO THE NEXT PAGE



DO NOT WRITE IN THIS AREA

SECTION II

Answer TWO questions in this section.

ALGEBRA AND RELATIONS, FUNCTIONS AND GRAPHS

9. (a) The functions $f(x)$ and $g(x)$ are defined as $f(x) = 2x - 7$ and $g(x) = x^2 + 1$, respectively.

(i) Write an expression, in terms of x , for EACH of the following:

- $f^{-1}(x)$

- $g^{-1}(x)$

- $fg(x)$

GO ON TO THE NEXT PAGE



DO NOT WRITE IN THIS AREA

- $(fg)^{-1}x$

(4 marks)

(ii) Show that $(fg)^{-1}(5) = g^{-1}f^{-1}(5)$.

(3 marks)

GO ON TO THE NEXT PAGE



- (b) The distance–time graph below shows the three-stage journey of a car travelling from Town *A* to Town *C* and back to Town *A*.

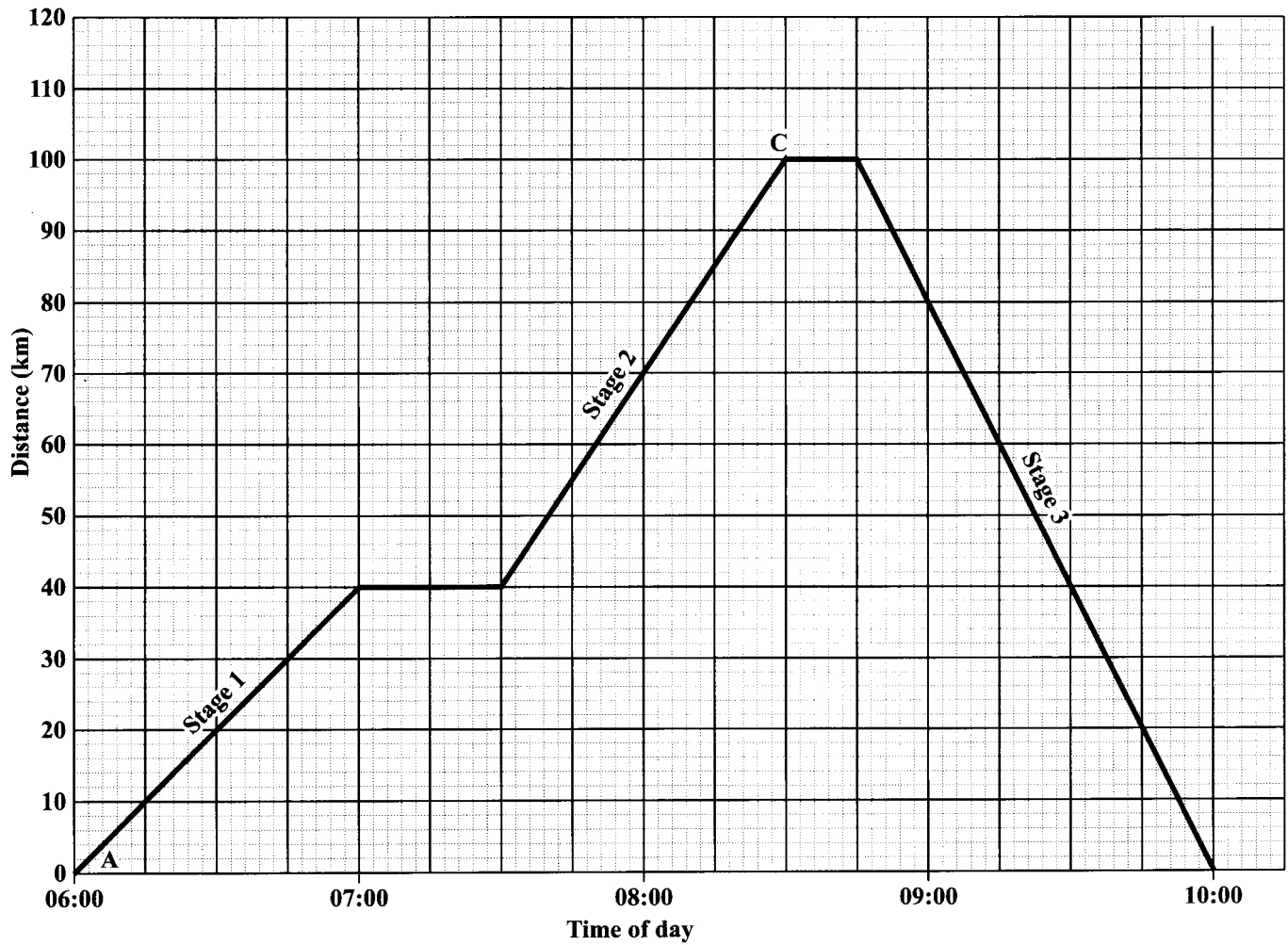

GO ON TO THE NEXT PAGE



DO NOT WRITE IN THIS AREA

- (i) State the time of day at which the car arrived at Town C.

.....
(1 mark)

- (ii) Calculate the TOTAL time, in minutes, for which the car stopped during the journey.

(2 marks)

- (iii) Determine the constant speed of the car during Stage 2 of the journey.

(2 marks)

- (iv) Calculate the average speed of the car for the time during which it was moving.

(3 marks)

Total 15 marks

GO ON TO THE NEXT PAGE



MEASUREMENT, GEOMETRY AND TRIGONOMETRY

10. (a) The diagram below, **not drawn to scale**, shows a circle, centre O . EH and EF are tangents to the circle. FOG and JOH are straight lines. The measure of $\angle FEH = 44^\circ$.

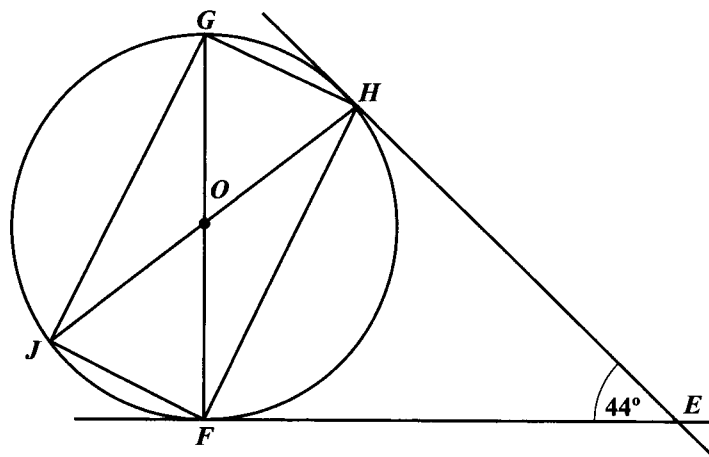

Calculate, giving reasons for your answer, the measure of:

(i) $\angle EHF = \dots\dots\dots$

(2 marks)

(ii) $\angle FGH = \dots\dots\dots$

(2 marks)

(iii) $\angle JHE = \dots\dots\dots$

(2 marks)

(iv) $\angle JGH \dots\dots\dots$

(2 marks)

GO ON TO THE NEXT PAGE



DO NOT WRITE IN THIS AREA

- (b) The diagram below, **not drawn to scale**, shows two ships, R and S at anchor on a lake of calm water. FT is a vertical tower. FSR is a straight line and $RS = 150$ m. The angles of elevation of T , the top of a tower, from R and S , are 22° and 40° respectively. F is the foot of the tower.

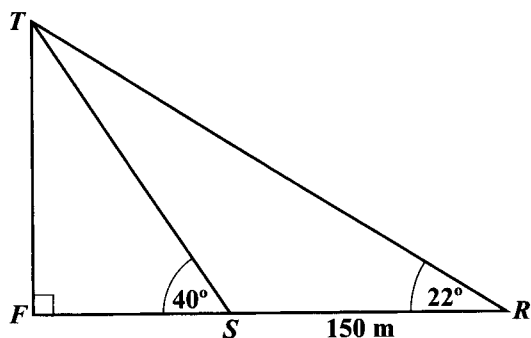

Calculate, giving your answer to 1 decimal place where appropriate

- (i) the measure of $\angle RTS$

(1 mark)

- (ii) the length of ST

(3 marks)

- (iii) the height of the tower, FT .

(3 marks)

Total 15 marks

GO ON TO THE NEXT PAGE



VECTORS AND MATRICES

11. (a) The position vectors of points A , B and C , relative to the origin O , are

$$\vec{OA} = \begin{pmatrix} 2 \\ -2 \end{pmatrix}; \vec{OB} = \begin{pmatrix} 6 \\ 1 \end{pmatrix} \text{ and } \vec{OC} = \begin{pmatrix} 10 \\ 4 \end{pmatrix} \text{ respectively.}$$

(i) Express in the form $\begin{pmatrix} x \\ y \end{pmatrix}$ the vectors

• $\vec{AB} = \dots\dots\dots$

• $\vec{AC} = \dots\dots\dots$

(3 marks)

(ii) Hence, determine whether A , B and C are collinear, **giving the reasons for your answer.**

.....

.....

.....

(3 marks)

GO ON TO THE NEXT PAGE



DO NOT WRITE IN THIS AREA

- (b) Determine the value of x for which the matrix $\begin{pmatrix} 3 & x \\ 2 & 4 \end{pmatrix}$ is singular.

(2 marks)

- (c) N and P are 2×2 matrices such that $N = \begin{pmatrix} 4 & 1 \\ 3 & 2 \end{pmatrix}$ and $P = \begin{pmatrix} 1 & 5 \\ 2 & 1 \end{pmatrix}$.

- (i) Determine NP .

(1 mark)

- (ii) Given that $PN = \begin{pmatrix} 19 & 11 \\ 11 & 4 \end{pmatrix}$, determine whether matrix multiplication is commutative.

(1 mark)

GO ON TO THE NEXT PAGE



(iii) Determine N^{-1} , the inverse of N .

(2 marks)

(iv) Hence, calculate the values of x and y for which $\begin{pmatrix} 4 & 1 \\ 3 & 2 \end{pmatrix} \begin{pmatrix} x \\ y \end{pmatrix} = \begin{pmatrix} 1 \\ 2 \end{pmatrix}$.

(3 marks)

Total 15 marks

END OF TEST

IF YOU FINISH BEFORE TIME IS CALLED, CHECK YOUR WORK ON THIS TEST.



0123402030

01234020/F 2016